

ITEM NO.	DESCRIPTION	QTY.	CODE	LENGTH(mm)
1	90MM PIPE FLOAT SET	2	MTF90	600
KIT	STANDARD GALVANISED FASTENER KIT INCLUDES:	1	MTF-GK-01	
2	12MM BOLTS	4		100
3	12MM NUTS	4		
4	BOLT RETAINER INSERTS	8		
5	12MM WASHERS	8		
OPTIONAL	STAINLESS STEEL FASTENER KIT	1	MTF-SK-01	100
OPTIONAL	REDUCER BUSH-SET	2	MTF-B-02	

NOTES:

MATERIAL:
LLDPE MATERIAL DESIGNED SPECIFICALLY FOR ROTATIONAL MOULDING APPLICATIONS DELIVERING A HIGH ESCR, CHEMICAL RESISTANCE, STIFFNESS AND TOUGHNESS WHICH IS UV STABILISED TO PROVIDE PROLONGED OUTDOOR PROTECTION IN HARSH CONDITIONS.

DIMENSIONS:
DIMENSIONS MAY VARY SLIGHTLY DUE TO THE SHRINKAGE NATURE OF POLYETHYLENE.

REFER TO TECHNICAL DATA SHEET FOR FURTHER PRODUCT DETAILS AND INSTALLATION INFORMATION.

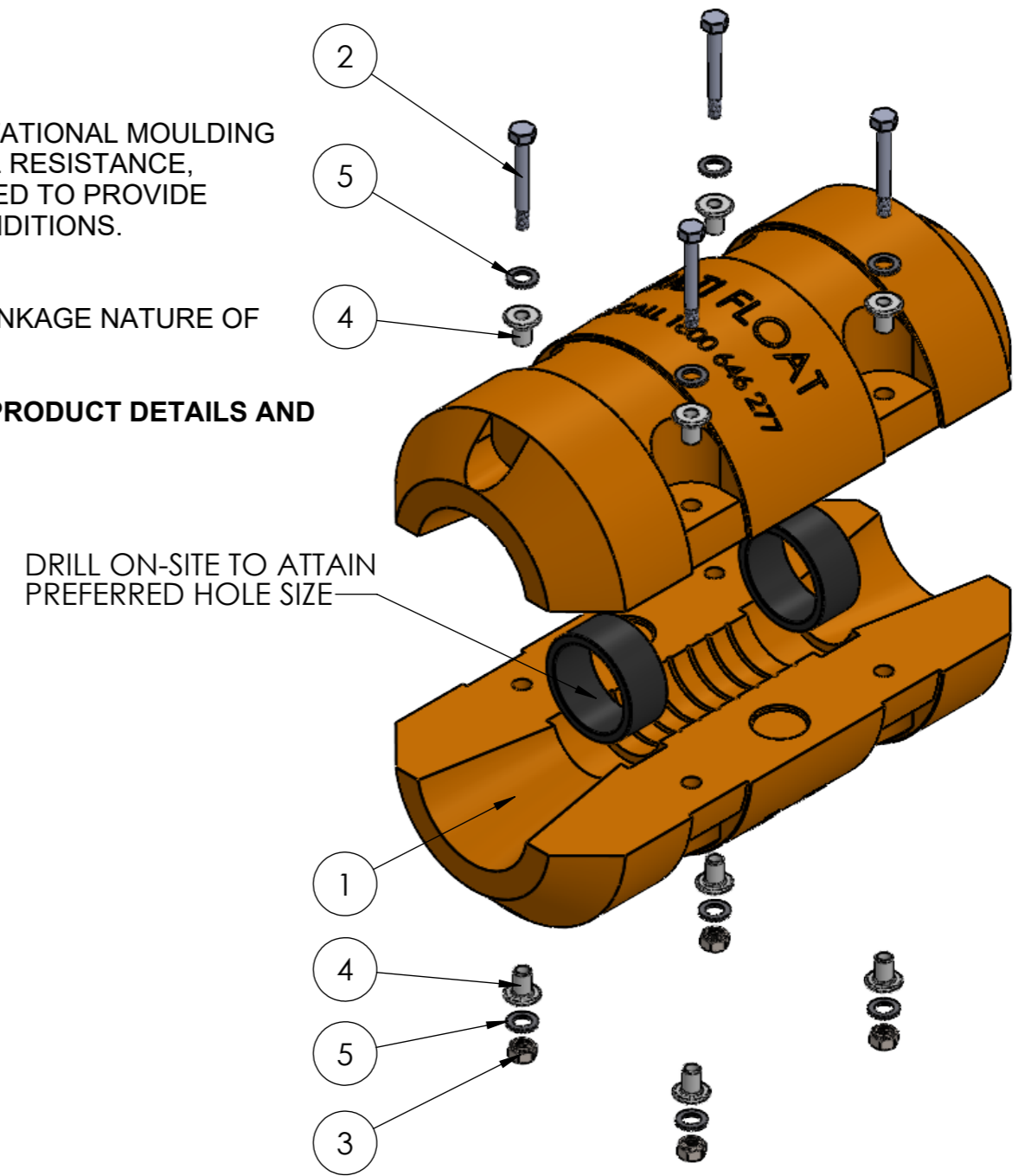
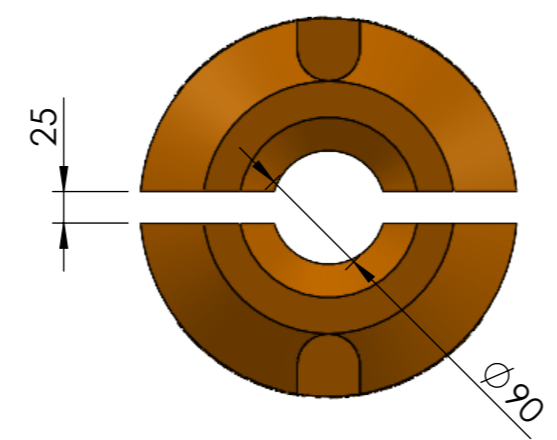
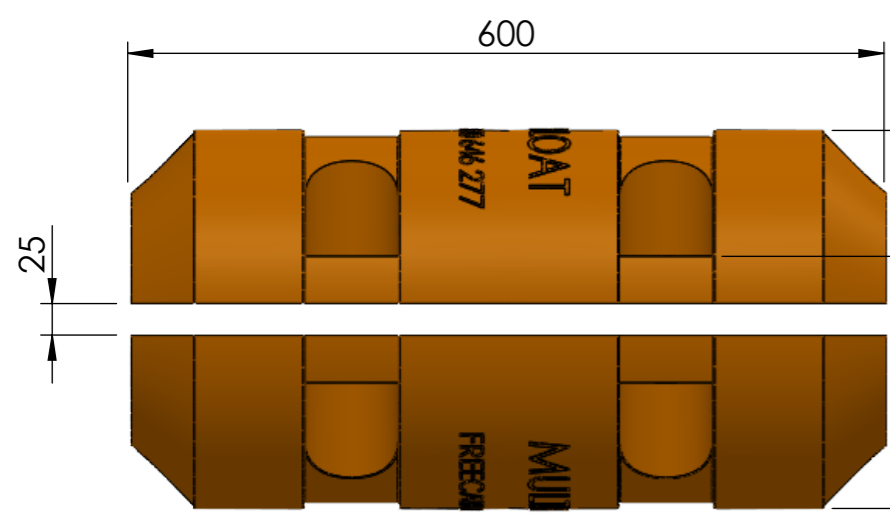
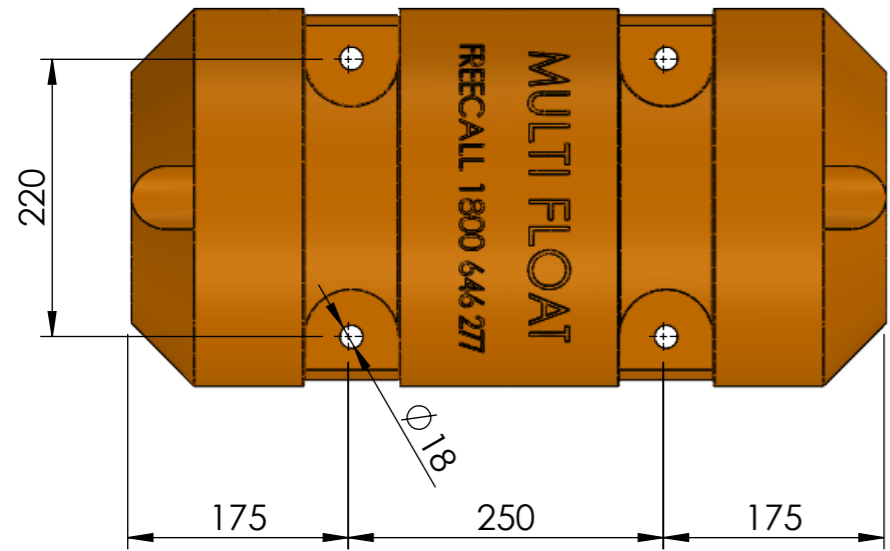

PIPE FLOAT SET WEIGHT: 5.5kg

REV	DESCRIPTION	DWN	CHK	APP	DATE
02	UPDATED TEMPLATE AND TABLE	JT	RB	MJ	10.11.23
01	ISSUED FOR CONSTRUCTION	MI			14.07.22

MATERIAL	LLDPE	DWN	JT
COLOUR/ FINISH	-	CHK	RB
S.G.	-	APP	MJ
		SCALE: NTS	

STOCK CODE	MTF90
PRODUCT	90mm HOSE FLOAT

PROPRIETARY. Neither this document nor its contents may be used or reproduced in any manner without the written authorisation of COERCO. Unless otherwise noted all dimensions are in millimetres.

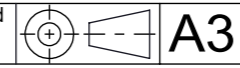

COERCO
23 Harris Rd, Malaga Western Australia 6090

Phone: 1800 646 277
E-mail: info@coerco.com.au

SHEET 1 OF 1	DWG NO.	MTF90_GA_001	REV. 02
--------------	---------	---------------------	----------------