

ITEM NO.	DESCRIPTION	QTY.	CODE	LENGTH(mm)
1	75MM PIPE FLOAT SET	2	MTF75	600
KIT	STANDARD GALVANISED FASTENER KIT INCLUDES:	1	MTF-GK-02	
2	12MM BOLTS	4		130
3	12MM NUTS	4		
4	BOLT RETAINER INSERTS	8		
5	12MM WASHERS	8		
OPTIONAL	STAINLESS STEEL FASTENER KIT	1	MTF-SK-02	130
OPTIONAL	REDUCER BUSH - SET	2	MTF-B-01	

NOTES:

MATERIAL:
LLDPE MATERIAL DESIGNED SPECIFICALLY FOR ROTATIONAL MOULDING APPLICATIONS DELIVERING A HIGH ESCR, CHEMICAL RESISTANCE, STIFFNESS AND TOUGHNESS WHICH IS UV STABILISED TO PROVIDE PROLONGED OUTDOOR PROTECTION IN HARSH CONDITIONS.

DIMENSIONS:
DIMENSIONS MAY VARY SLIGHTLY DUE TO THE SHRINKAGE NATURE OF POLYETHYLENE.

REFER TO TECHNICAL DATA SHEET FOR FURTHER PRODUCT DETAILS AND INSTALLATION INFORMATION.

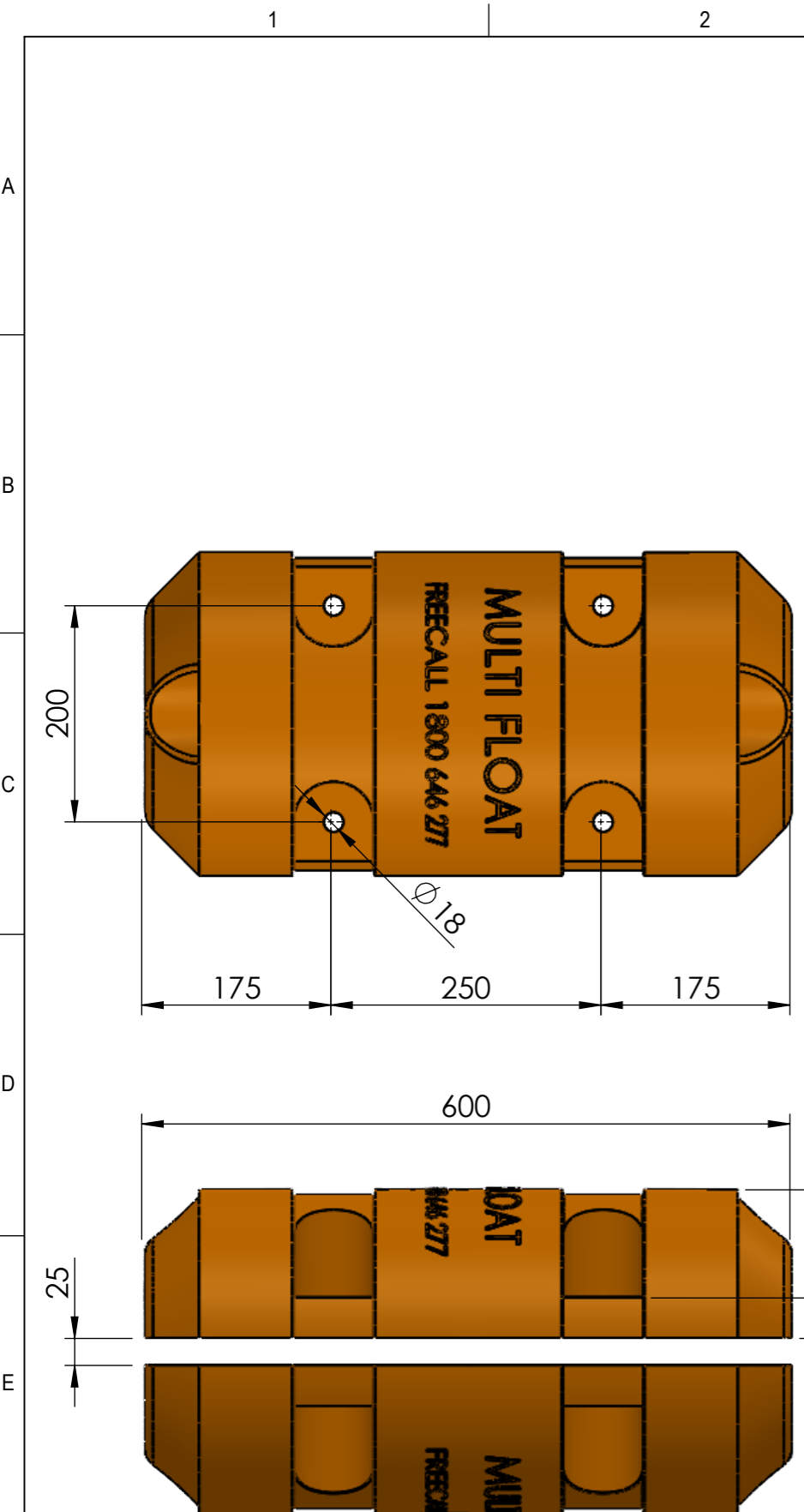

DRILL ON-SITE TO ATTAIN PREFERRED HOLE SIZE

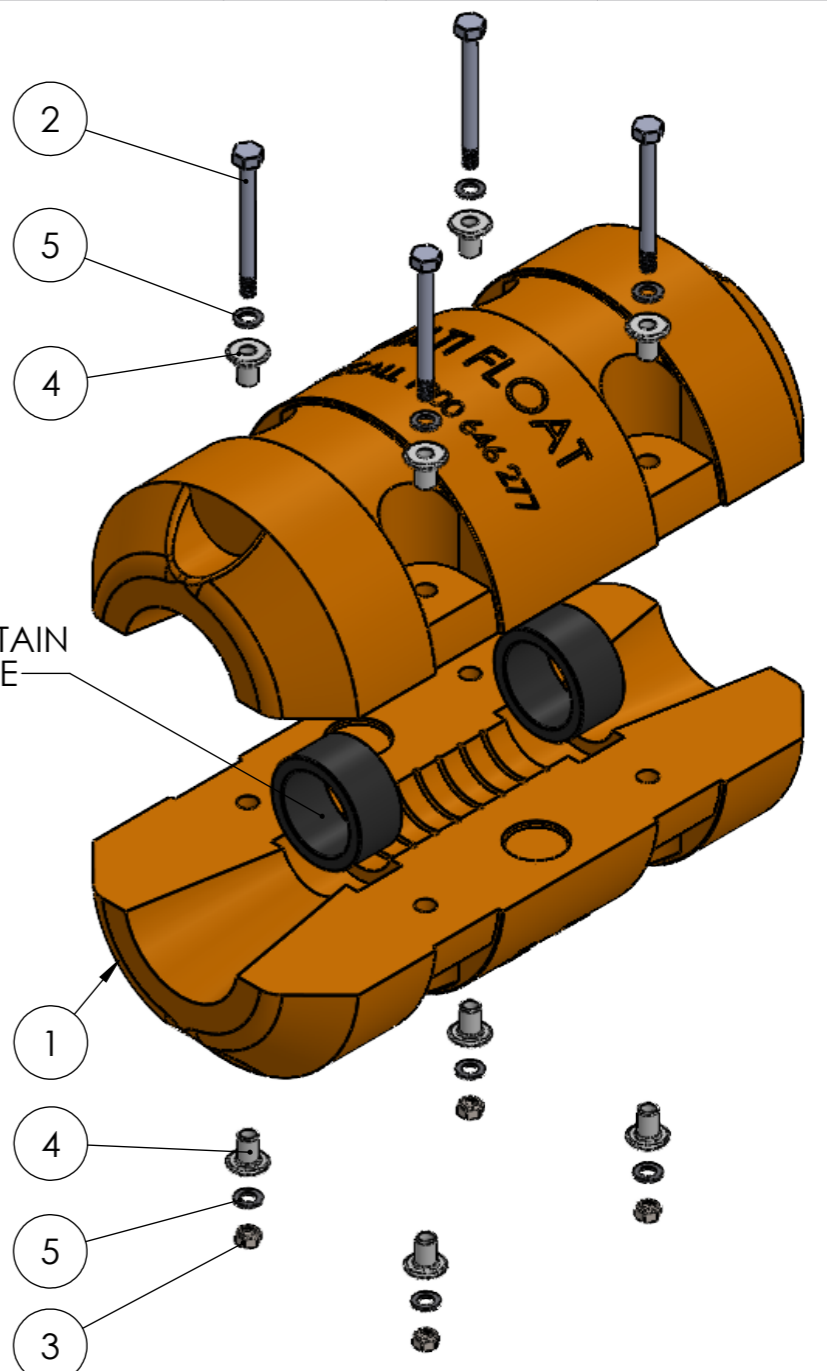

PIPE FLOAT SET WEIGHT: 5.5kg

REV	DESCRIPTION	DWN	CHK	APP	DATE
02	UPDATED TEMPLATE AND TABLE	JT	RB	MJ	02.11.23
01	ISSUED FOR CONSTRUCTION	MI			14.07.22

coerco
Engineered Project Solutions

MATERIAL	LLDPE	DWN	JT
COLOUR/FINISH	-	CHK	RB
S.G.	-	APP	MJ
		SCALE: NTS	

STOCK CODE	MTF75
PRODUCT	75mm HOSE FLOAT